



RC 472 705

Fully integrated
Width 30" (76.2 cm)

Included accessories

1 egg holder with lid

Installation accessories

RA 421 713

Stainless steel door panel with handle
For 30" (76.2 cm) wide appliances,
panel thickness ¾".

RA 423 140

Side trims, long.

RA 425 110

Stainless steel handle for
refrigerator door.
With 3 mounts, length 44 ½" (1.131 mm).

RA 428 713

Stainless steel door panel, **handleless**
For 30" (76.2 cm) wide appliances,
panel thickness ¾".

RA 460 000

Accessory for side-by-side installation.
Not required if appliances are installed
more than 6 ⅝" apart from each other.
Included in delivery for RF and RW

RA 460 012

Additional side heating element 110 V.
Required if appliances are installed with
a distance greater than 5" and less than
6 ⅝" next to each other and for all built-in
situations in a very humid environment.
Not required if appliances are installed
more than 6 ⅝" apart from each other.

RA 460 020

Connecting element for vertically split
appliance fronts (for a flush front).

RA 464 711

Ventilation grill stainless steel
For RC 472 30" (76.2 cm) wide
appliances.

Optional accessories

RA 430 100

Storage container with transparent lid,
anthracite

Part #11031964

Egg holder insert (for use with RA
430 100)

Vario 400 series refrigeration column RC 472

- Stainless steel interior with solid anthracite aluminium elements
- Warm white and glare-free LED light spots
- Opening assist for door with two options:
 1. Push-to-open function for integration into handleless cabinet front
 2. Pull-to-open function to facilitate opening the door using a handle
- The drawers in the RC and RF models are positioned at the same height. With side-by-side installation, the glass shelves and door bins can be aligned on the same level
- Flat stainless steel inner door, full-length
- Almost invisible rail system for shelves and door bins for flexible positioning
- Solid anthracite aluminium door bins
- One fresh cooling drawer 32 °F (0 °C) with manually adjustable temperature and one fresh cooling drawer with manually adjustable humidity
- TFT touch display
- ENERGY STAR® certified
- Sabbath mode certified by Star-K
- Net volume 16.8 cu.ft.

Operation

TFT touch display operation.
Clear text display in 52 languages.

Features

Dynamic cold air distribution with Multi-Flow Air System.
Automatic defrosting with defrost water evaporation.
Cushioned door closing system.
Activated charcoal air filter.
When rest mode (Sabbath mode) is active, the appliance can only be opened using a handle.
Open-door and malfunction alarm.

Home network integration for digital services (Home Connect) wireless via WiFi. The use of the Home Connect functionality depends on the Home Connect services, which are not available in every country.
For further information please check: home-connect.com.

Cooling

No-Frost technology with fast cooling.
Temperature adjustable from 35 °F to 46 °F (+2 °C to +8 °C).
3 safety glass shelves, white glass, individually adjustable in height.
1 shallow, fully extendable drawer with transparent front.
1 integrated shelf with satin-finished glass.
Cushioned closing system.
4 brilliant LED light spots with warm white, glare-free light within cooling area and drawers.
Flat door rail system with fully flexible positioning of door bins.
4 height-adjustable door bins, one of which is a large gallon door bin.
Net volume 16.8 cu.ft.

Fresh cooling close to 32 °F (0 °C)
1 large, fully extendable fresh cooling 32 °F (0 °C) drawer with transparent front, illuminated.
Cushioned closing system.
Temperature control via central TFT display, temperature can be adjusted from 30 °F to 38 °F (-1 °C to +3 °C).
Ideal for meat, fish and poultry.

Fresh cooling

1 fully extendable fresh cooling drawer with transparent front, illuminated.
Cushioned closing system.
Humidity can be adjusted manually.
Ideal for fruit and vegetables.

Consumption data

Energy consumption 279 kWh/year.
Noise level 40 dB(A) re 1 pW.

Planning notes

Flat hinge.
Door hinge right, reversible.
Door opening angle of 115°, fixable at 90°.
Max. door panel weight: 53 lbs. (24 kg).

Rating

Total rating: 760 W/24h.
Total Amps: 10 A.
120 V / 60 Hz
Connecting cable 118" (3.0 m), detachable.

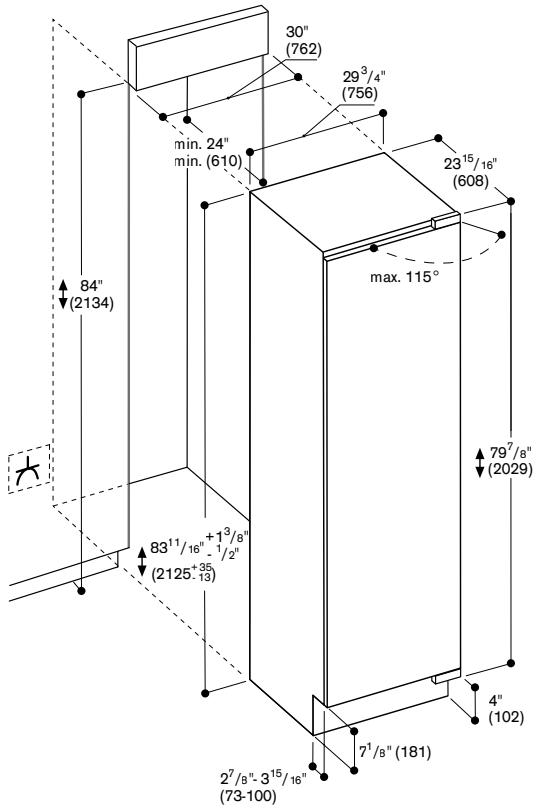

The door face dimensions are designed for a maximum gap of 1/8" (3 mm).