

Integrated Double DishDrawer™ Dishwasher, Tall, Sanitize

Series 9 | Integrated

Panel Ready



Doing the dishes got easier. Load one drawer while the other washes - with the top drawer fitting your large dinner plates easily.

- Knock to pause function is perfect if you miss a dish
- Six wash programs, as well as additional Quick wash, Sanitize and Extra Dry options
- Built-in water softener improves wash performance by reducing unwanted minerals in the water

- Customize with your own kitchen cabinetry or purchase our stainless steel door panel accessory

DIMENSIONS

Height	34 - 36 3/8"
Width	23 9/16"
Depth	22 1/2"

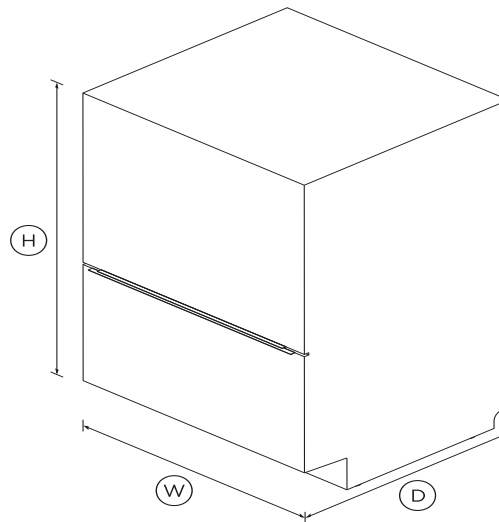

SPECIFICATIONS

Accessories

- Kickstrip
- Knife clip and multipurpose

Accessories (sold separately)

Door panel stainless steel	ADDD24DTPX
Handle kit Contemporary	AHS-OBDD-60S
Handle kit Contemporary	AHD5-OBDD-60SX
Handle kit Contemporary	AHD3-OBDD-60S
Handle kit Professional round	AHP3-DWDD-SX

Capacity and loading

Accommodates round plates	12.25" (top) 11" (bottom)
Adjustable height, foldable	•
Fold down tines	•
Pitch adjustable tines	•
Place settings	14
Place settings per drawer	7

Consumption

Energy usage	265kWh/year
Water usage (per wash cycle)	3.44 gal running both tubs

Controls

- Child lock
- Electronic fault/Diagnostic
- End of cycle beeps
- Energy saving delay start
- Internal wash selector
- Knock to pause
- Rinse aid indicator light
- Wi-Fi connectivity

Features

- Built-in water softener

Fan assisted drying	•
Flow through detergent	•
Motor type	BLDC
Quiet operation	•
SmartDrive™ technology	•

Performance

Noise on standard cycle top	43dBA
-----------------------------	--------------

Power requirements

Amperage	10A
Electric circuit	3 wire
Rated current	15A
Supply frequency	60Hz
Supply voltage	100 - 120V

Product dimensions

Depth	22 1/2"
Height	34 - 36 3/8"
Width	23 9/16"

Warranty

Parts and labor	Limited 2 years
-----------------	------------------------

Wash Program Modifiers

Extra Dry	•
Quick	•
Sanitize	•

Wash Programs

Delicate	•
Eco	•
Fast	•
Heavy	•
Medium	•
Rinse	•
Wash programs	6

Water connection

Supplied hose to suit 3/8"	•
Water pressure	100kPa - 1000kPa
Water supply	3/8" to suit Male Compression

SKU	82337
-----	--------------

The product dimensions and specifications in this page apply to the specific product and model. Under our policy of continuous improvement, these dimensions and specifications may change at any time. You should therefore check with Fisher & Paykel's Customer Care Centre to ensure this page correctly describes the model currently available. ? Fisher & Paykel Appliances Ltd 2020

Other product downloads available at fisherpaykel.com

- [↓](#) Quick Start Guide
- [↓](#) Service & Warranty
- [↓](#) Energy Label Integrated Double DishDrawer™ Dishwasher
- [↓](#) User Guide DishDrawer™ Dishwasher
- [↓](#) Installation Guide Double DishDrawer™ Dishwasher
- [↓](#) Data Sheet Integrated Double DishDrawer™ Dishwasher



A PEACE OF MIND SALE

24 Hours 7 Days a Week Customer Support

T 1.888.936.7872 Wwww.fisherpaykel.com