

Single DishDrawer™ Dishwasher, Tall, Sanitize

Series 9 | Professional

Stainless Steel

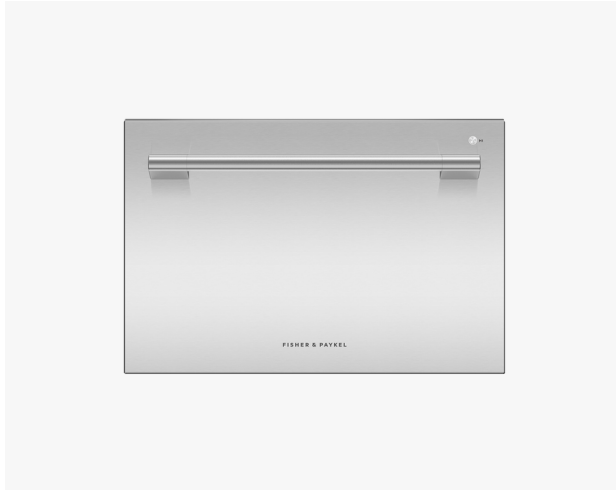

Designed to fit your full-sized dinner plates, this DishDrawer™ can be placed anywhere in your kitchen, for loading dishes with less bending.

- Six wash programs, as well as additional Quick wash, Sanitize and Extra Dry options
- American Disabilities Act (ADA) compliant, this can be installed at an accessible height for loading and unloading.
- Flexible racking can be folded down to fit bigger dishes

DIMENSIONS

Height	17 7/8"
Width	23 9/16"
Depth	22 3/4"

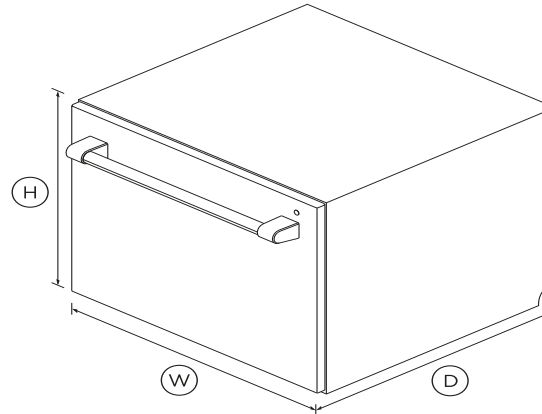

FEATURES & BENEFITS

EASE OF USE

DishDrawer™ Dishwashers are as easy to open and close as kitchen drawers and can be conveniently positioned at bench height for ease of loading and minimal bending. Flexible racking allows you to make adjustments to fit in a variety of dishes.

COMPLEMENTARY DESIGN

DishDrawer™ Dishwashers can be installed in any kitchen space and are designed to match the Fisher & Paykel family of kitchen appliances, with matching handles, premium styling and quality

materials.

QUICK, SANITIZE AND EXTRA DRY OPTIONS

The Quick wash modifier delivers a faster wash while maintaining performance. The Sanitize option provides extra protection killing 99.9% of bacteria in the final rinse. The Extra Dry setting is perfect for plastic dishes.

QUIET PERFORMER

Running at a very low decibel rate, these DishDrawer™ Dishwashers do their job without making a fuss. The combination of intelligent technology and simple mechanics means greater reliability and excellent wash performance.

SPECIFICATIONS

Accessories

- Cutlery basket
- Kickstrip

Capacity and loading

Accommodates round plates	11"
Adjustable height, foldable	•
Fold down tines	•
Pitch adjustable tines	•
Place settings	7

Consumption

Energy rating	Energy star
Energy usage	144kWh/year
Water usage (per wash cycle)	1.64 gal

Controls

- Child lock

- Electronic fault/Diagnostic
- End of cycle beeps
- Energy saving delay start
- Internal wash selector
- One button start
- Rinse aid indicator light
- Wi-Fi connectivity

Features

- Fan assisted drying
- Flood protection
- Flow through detergent
- Quiet operation
- SmartDrive™ technology

Performance

Noise emissions **42dBA**

Power requirements

Amperage **5A**
 Electric circuit **3 wire**
 Rated current **15A**
 Supply frequency **60Hz**
 Supply voltage **100 - 120V**

Product dimensions

Depth **22 3/4"**
 Height **17 7/8"**
 Width **23 9/16"**

Safety and compliance

ADA compliant •

Warranty

Parts and labor **Limited 2 years**

Wash Program Modifiers

Extra Dry •
 Quick •
 Sanitize •
 Wash modifiers **3**

Wash Programs

Delicate •
 Eco •
 Fast •
 Heavy •
 Medium •
 Rinse •
 Wash programs **6**

Water connection

Inlet water temperature **Max 140°F**
 Supplied hose to suit 3/8" •
 Water pressure **30kPa - 1000 kPa**
 Water supply **3/8" to suit Male Compression**

SKU **82346**

The product dimensions and specifications in this page apply to the specific product and model. Under our policy of continuous improvement, these dimensions and specifications may change at any time. You should therefore check with Fisher & Paykel's Customer Care Centre to ensure this page correctly describes the model currently available. ? Fisher & Paykel Appliances Ltd 2020

Other product downloads available at fisherpaykel.com

- [↓](#) Service & Warranty
- [↓](#) Energy Label Single DishDrawer™ Dishwasher
- [↓](#) User Guide DishDrawer™ Dishwasher
- [↓](#) Quick Start Guide DishDrawer™ Dishwasher
- [↓](#) Installation Guide Single DishDrawer™ Dishwasher



A PEACE OF MIND SALE

24 Hours 7 Days a Week Customer Support

T 1.888.936.7872 **W** www.fisherpaykel.com