

Double Oven, 30", 8.2 cu ft, 17 Function, Self-cleaning

Series 9 | Professional

Stainless Steel



Choose maximum capacity, combining two independent ovens so you can cook dishes simultaneously, with touchscreen for ease of use.

- Guided cooking using your touchscreen makes it simple to cook by food, function or recipe.
- 4.1 + 4.1 cu ft total capacity across two oven cavities, with 17 oven functions
- Non-tip, full extension sliding shelves for safe removal of hot dishes
- Accessories include food probe, smokeless grill tray, and more

DIMENSIONS

Height	48 7/16"
Width	29 29/32"
Depth	23 29/32"

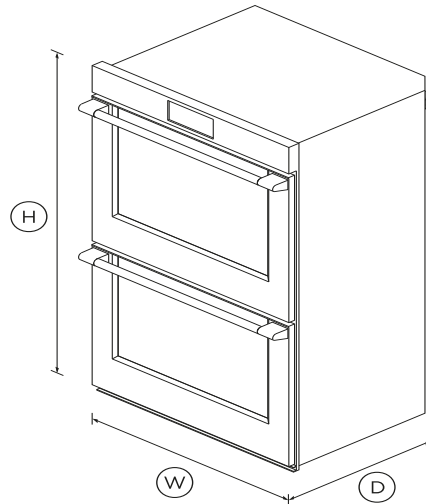

FEATURES & BENEFITS

COOK WITH CONFIDENCE

Our touchscreen interface provides an intuitive guided cooking experience that helps deliver perfect results, whether you've been cooking all your life or just starting out. Cook with a favorite method, a hero ingredient, or a go-to cooking function or recipe.

GENEROUS CAPACITY

With an incredible 4.1 cu ft total capacity in each oven, you can

create several perfectly cooked dishes at once using multiple shelves.

MULTI-FUNCTION FLEXIBILITY

The cooking functions have each been tailored, tested, tweaked and perfected to ensure that no matter what you're cooking, you've got the right heat to match. Purchase our Wireless Temperature Sensor accessory and precisely monitor cooking in real time (accessory sold separately).

EXCEPTIONAL PERFORMANCE

AeroTech circulates heat evenly for a consistent temperature throughout the cavity, helping you ensure perfect results even when cooking on multiple shelves.

SELF-CLEANING

Our self-clean technology breaks down food residue at a very high temperature, leaving a light ash that's easily removed with a damp cloth. The enamel coated side racks don't need to be removed when using this function.

DESIGN FREEDOM

Designed to fit seamlessly into your kitchen, this built-in oven features premium materials and elegant styling to support a cohesive, considered kitchen design.

SPECIFICATIONS

Accessories

Broil rack	1 set
Full extension sliding shelves	5 sets
Roasting pan	1
Smokeless broil tray	1
Wired temperature sensor	1

Capacity

Shelf positions	16
-----------------	----

Total capacity **8.2cu ft**

Cleaning

- Acid resistant graphite enamel •
- Removable oven door •
- Removable shelf runners •

Controls

- Adjustable audio and display •
- Automatic cooking/minute •
- Automatic pre-set •
- Celsius/Fahrenheit •
- Electronic clock •
- Electronic oven control •
- Food probe •
- Guided cooking by food type •
- Intuitive touchscreen display •
- Multi-language display **UK English, US English,** •
- Sabbath mode with Star K •
- Wi-Fi connectivity •

Functions

- Aero Bake •
- Aero Broil •
- Air fry •
- Bake •
- Broil •
- Classic bake •
- Dehydrate •
- Maxi Broil •

- Number of functions **17**
- Pastry Bake •
- Pizza bake •
- Rapid proof •
- Roast •
- Self-clean •
- Slow cook •
- True Aero •
- Vent bake •
- Warm •

Performance

- AeroTech™ technology •
- Automatic rapid pre-heat •
- Broil power **4400W**
- Broil width **20"**
- Number of passes on Maxi **12**
- Number of passes on broil **10**

Power requirements

- Amperage **33.2 - 38.3A**
- Supply voltage **208 / 240V**

Product dimensions

- Depth **23 29/32"**
- Height **48 7/16"**
- Width **29 29/32"**

Safety

- ADA compliant •

- Balanced oven door •
- Catalytic venting system •
- Control panel key lock •
- CoolTouch door •
- Non-tip shelves •

SKU **81920**

The product dimensions and specifications in this page apply to the specific product and model. Under our policy of continuous improvement, these dimensions and specifications may change at any time. You should therefore check with Fisher & Paykel's Customer Care Centre to ensure this page correctly describes the model currently available. ? Fisher & Paykel Appliances Ltd 2020

Other product downloads available at fisherpaykel.com



User Guide



Service & Warranty



User Guide Built-In Oven



Installation Guide



Specification Guide Double Oven



Data Sheet Double Oven



A PEACE OF MIND SALE

24 Hours 7 Days a Week Customer Support

T 1.888.936.7872 **W** www.fisherpaykel.com