

Double Oven, 30", 10 Function, Self-cleaning

Series 7 | Professional

Stainless Steel



Choose maximum capacity, combining two independent ovens so you can cook multiple dishes simultaneously.

- 4.1 + 4.1 cu ft total capacity across two oven cavities
- 10 functions in each oven including Roast and Aero™ Pastry
- High-temperature self-cleaning function breaks down food residue for an easy clean
- Non-tip, full-extension shelves for safe removal of hot dishes

DIMENSIONS

| | |
|--------|----------|
| Height | 48 1/2" |
| Width | 29 3/4" |
| Depth | 23 5/16" |

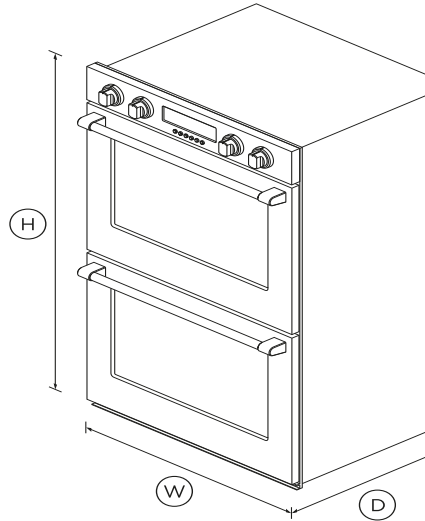

FEATURES & BENEFITS

COOKING FLEXIBILITY

This built-in oven has 10 functions with pre-set temperatures, including Roast, Pastry Bake and Maxi Broil allowing you to use a variety of cooking styles.

EVEN COOKING

A digital microprocessor monitors the temperature to ensure precise heat and a four-way convection system creates even heat distribution throughout the oven, ideal for multi-shelf cooking.

SIZED TO SUIT

This is one of the largest built-in ovens on the market providing

8.2 cu ft total capacity across two oven cavities allowing you to fit a large casserole dish, the family roast and a pie for dessert.

SELF CLEANING

The self-clean function breaks down food residue at a very high temperature, leaving a light ash that's easily removed with a damp cloth. For best results, wipe down the inside of your oven door before you use the self-clean function.

INFORMATION AT A GLANCE

Halo illuminated dials provide information at a glance. White – heating up; orange – temperature is reached; red – self-cleaning mode. Three halogen lights and the large oven window creates excellent visibility of what's cooking.

SAFE AND SOUND

The CoolTouch door with triple glazing and cooling system is safe to touch from the outside, protecting your hands and the surrounding cabinetry.

SPECIFICATIONS

Accessories

| | |
|--------------------------------|--------|
| Full extension sliding shelves | 5 sets |
|--------------------------------|--------|

Capacity

| | |
|-----------------|----------|
| Shelf positions | 8 |
| Total capacity | 8.2cu ft |
| Usable capacity | 7.2cu ft |

Cleaning

| | |
|--------------------------------|---|
| Acid resistant graphite enamel | • |
| Pyrolytic self-clean | • |
| Removable oven door | • |
| Removable shelf runners | • |

Controls

- Audio feedback
- Automatic cooking/minute
- Automatic pre-set
- Celsius/Fahrenheit
- Delay start
- Electronic clock
- Electronic oven control
- Halogen lights
- Intuitive touchscreen display
- LED display
- Turned stainless capacitive

Functions

- Bake
- Broil
- Convection Broil
- Convection bake
- Convection pastry
- Maxi Broil
- Maxi Grill
- Number of functions **10**
- Pastry Bake
- Pastry Bake with Pizza mode
- Roast
- Self-clean
- True convection
- Warm

Performance

- AeroTech™ technology
- Automatic rapid pre-heat
- Broil power **4400W**

Power requirements

- Amperage **50A**
- Supply frequency **60Hz**
- Supply voltage **120/240V**

Product dimensions

- Depth **23 5/16"**
- Height **48 1/2"**
- Width **29 3/4"**

Safety

- ADA compliant
- Control panel key lock
- CoolTouch door
- Non-tip shelves
- Safety thermostat

Warranty

- Parts and labor **2 years**

SKU **81831**

specifications may change at any time. You should therefore check with Fisher & Paykel's Customer Care Centre to ensure this page correctly describes the model currently available. ? Fisher & Paykel Appliances Ltd 2020

The product dimensions and specifications in this page apply to the specific product and model. Under our policy of continuous improvement, these dimensions and

Other product downloads available at fisherpaykel.com



Quick Start Guide



User Guide



Service & Warranty



Installation Guide



Data Sheet Double Oven



A PEACE OF MIND SALE

24 Hours 7 Days a Week Customer Support

T 1.888.936.7872 **W**www.fisherpaykel.com