

# 30-Inch Gas Cooktop

\$1,699 | TRANSITIONAL

**dacor**



DTG30P875NS/DA - Silver Stainless, Natural Gas

## Features & Benefits

- SimmerSear™ burners
- Illumina™ Knobs
- SmartThings Wi-Fi connectivity
- Auto Connect to compatible ventilation through Bluetooth
- LP conversion kit

## Controls

<b>CONTROL TYPE</b>	Knobs
<b>ILLUMINA™ KNOBS</b>	White
<b>WI-FI + SMARTTHINGS</b>	Yes
<b>SABBATH MODE</b>	Yes

## Cooktop

<b>NUMBER OF BURNERS</b>	5 Aluminum
<b>PERMA-FLAME™ (AUTO RE-IGNITION)</b>	No
<b>LEFT FRONT (BTU)</b>	9,500
<b>LEFT REAR (BTU)</b>	9,500
<b>CENTER (BTU)</b>	19,000
<b>RIGHT FRONT (BTU)</b>	13,000
<b>RIGHT REAR (BTU)</b>	9,500
<b>BRASS BURNER CAPS</b>	No
<b>GRIDDLE</b>	Yes
<b>WOK RING</b>	Yes

## Weights & Dimensions

<b>NET WEIGHT (LBS.)</b>	76
<b>SHIPPING WEIGHT (LBS.)</b>	84
<b>PRODUCT DIMENSIONS (W x H x D IN INCHES)</b>	30 x 3 ½ x 21
<b>CUTOUT REQUIRED (W x D IN INCHES)</b>	28 ½ x 19 ⅝

## Technical Details

<b>ELECTRICAL REQUIREMENTS</b>	120V, 60 Hz, 20A
<b>AVAILABLE FUEL TYPES</b>	Natural Gas, Liquid Propane
<b>LP CONVERSION KIT (INCLUDED)</b>	Yes

## Warranty

<b>FULL COVERAGE</b>	2 Years
----------------------	---------

# 30-Inch Gas Cooktop

**\$1,699 | TRANSITIONAL**

**dacor**

## Product Dimensions

<b>A - WIDTH (IN/MM)</b>	30 / 762
<b>B - CHASSIS WIDTH (IN/MM)</b>	28 1/8 / 715
<b>C - CHASSIS DEPTH (IN/MM)</b>	19 3/8 / 492

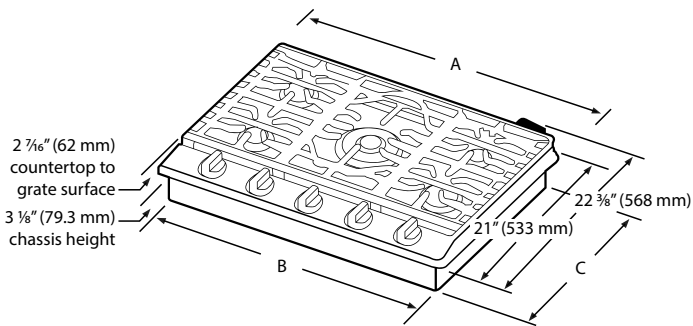

## Installation Cutout Dimensions

<b>E - MIN (IN/MM)</b>	2 7/8 / 73
<b>F - MIN (IN/MM)</b>	19 5/8 / 498.5
<b>G - MIN (IN/MM)</b>	28 1/2 / 723.9
<b>H - MIN (IN/MM)</b>	12 / 304.8

