



## QUIET COOL™ BUILT-IN 42" W. SIDE-BY-SIDE

Viking Professional 5 Series – FDSB

### PROCHILL TEMPERATURE MANAGEMENT SYSTEM

- ENERGY STAR Qualified
- Variable Speed DC Overdrive™ Compressor quickly chills food and saves energy
- Single compressor system is one of the quietest, most technologically advanced compressors available
- Electronic controls maintain even temperatures within one degree °F to keep food fresher longer
- Odor Eliminator™ Evaporator removes odors and excess humidity
- Maintenance-free Super Clog Resistant™ Condenser prevents dust and other airborne particles from clogging the condenser

### FILTER-FREE FRESHNESS

- **EXCLUSIVE** Plasmacluster™ Ion Air Purifier uses advanced ion technology to eliminate airborne bacteria, mold, and odors to enhance food preservation
- Functions at 100% capacity and never degrades, never needs replacing, and no maintenance is ever required

### THE LATEST IN SPILL CONTROL TECHNOLOGY

- New Spillproof Plus™ Shelves with Nano technology create an invisible barrier to contain spills
- Seamless glass shelves make cleanup easy and maximize usable space
- 3/8" thick tempered glass shelves provide industry-leading durability

### LED LIGHTING

- All items are in clear view with bright energy efficient LED lighting from top and sidewalls
- Ramp on theater lighting provides better visibility

### SPECIALIZED REFRIGERATION STORAGE

- One adjustable Humidity Zone™ Drawer with NEW soft-close slides
  - Humidity can be set high for leafy greens or low for fruits and vegetables with skins
- NEW Additional space for large pizza box storage
- Four deli drawers with soft-close slides
- Two in-the-door dairy compartments with covers
- Four Patented (three are adjustable) aluminum door bins securely store heavy items
- Adjustable door stops – 90, 110 and 120 degrees



### SPECIALIZED FREEZER STORAGE

- Three adjustable wire shelves for custom storage
- Two slide-out, large capacity wire baskets provide easy storage viewing
- Three patented adjustable aluminum door bins
- Adaptive defrost controls the timing of the defrost periods, instead of an electromechanical defrost timer
  - Extends to 96 hours – improves food storage because the unit defrosts less often
- Factory-installed automatic ice maker features large-capacity ice bucket
- Door alarm sounds and glows to warn that fresh food door and/or freezer drawer have been ajar for three minutes, and that the temperature has risen above normal operating range

### MODEL NUMBERS

- FDSB5423 – 42" W. Side-by-Side Refrigerator/Freezer – Custom Panel

### ACCESSORIES

- PHK28-SS Professional stainless steel handle (1 piece / 28")

### DESIGN OPTION

- Custom panel model (CFDSB) available to blend seamlessly into cabinetry with locally supplied front panels

### WARRANTY

- 2-year full covers complete unit
- 6-year full – sealed refrigeration system
- 12-year limited – sealed refrigeration system



# QUIET COOL™ BUILT-IN 42"W. SIDE-BY-SIDE

Viking Professional 5 Series – FDSB

42" W. SIDE-BY-SIDE FLUSH MOUNT TRIM AND CUSTOM DOOR OVERLAY	
DESCRIPTION	FDSB
Overall Width	42" (106.7 cm)
Overall Height from bottom	82-3/4" (210.2 cm) min. to 84-1/16" (213.5 cm) max.
Overall Depth from rear	To front edge of side trim: 25-1/2" (64.8) To front of top grille: 26-1/4" (66.7 cm) To front of handle endcap: 29-3/16" (74.1 cm)
Cutout Width	42" (106.7 cm)
Cutout Height	82-7/8" (210.5 cm) min. to 84-1/16" (213.5 cm) max.
Flush Mount Cutout depth	26-3/8" (67.0 cm) min.
Electrical Requirements	115 volt, 60 Hz, 15 amp dedicated circuit; 3-wire cord with grounded 3-prong plug attached to product
Maximum Amp Usage	9.9 amps
Inlet Water Requirements	1/4" copper tubing inlet waterline; minimum 20 psi; maximum 120 psi
Overall Interior Dimensions	
Refrigerator	15.76 cu. ft. (446 liters)
Freezer	9.56 cu. ft. (271 liters)
Total Capacity	25.32 cu. ft. (717 liters)
Approximate Shipping Weight	525 lb. (238 kg)

Please do not prepare installation from brochure data only. See installation instructions for important clearance/installation information.

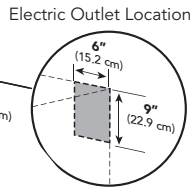
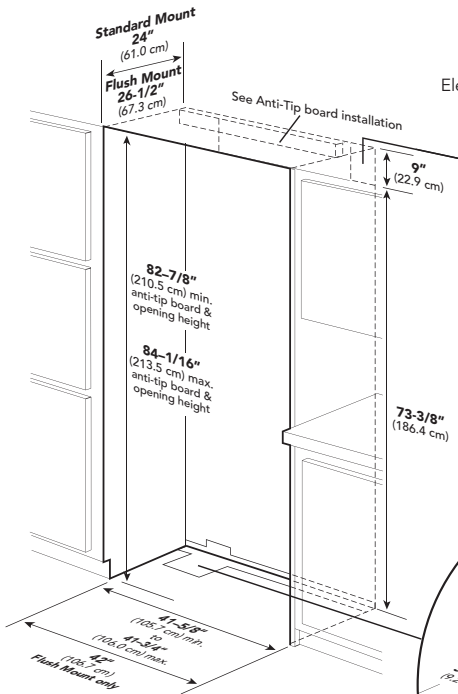
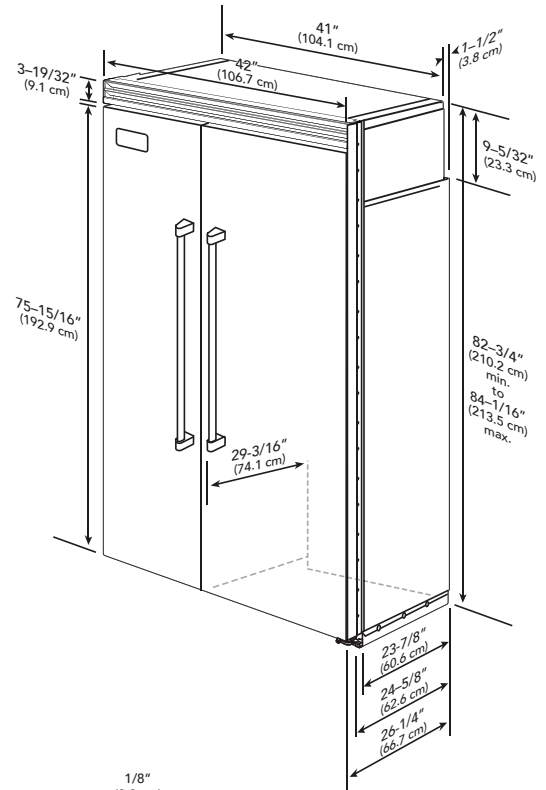

\*The face of the door skin needs to be on the same plane, flush with the cabinets. If the door face is pushed in past the surface of the cabinet, the door could run into cabinetry when it is in the full open position.

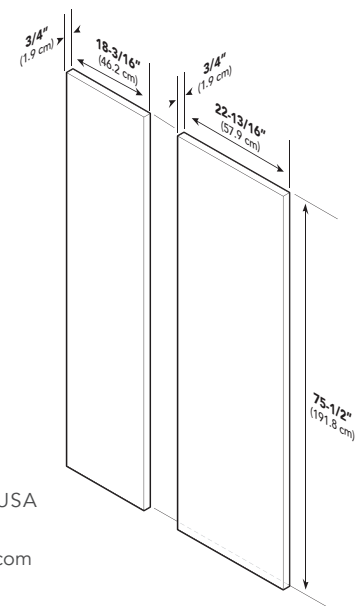
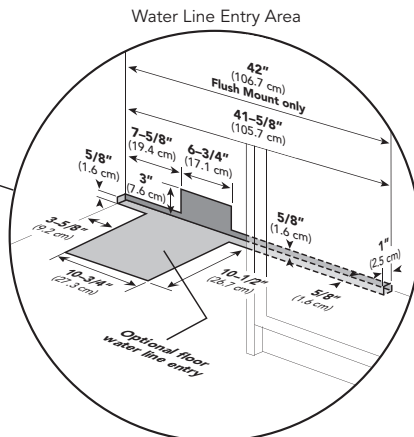
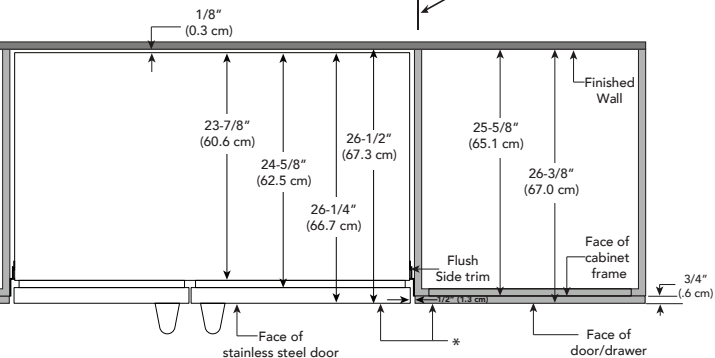

VIKING RANGE, LLC 111 FRONT STREET GREENWOOD, MISSISSIPPI 38930 USA

For detailed product information, model numbers, or to request a quote call 1-888-845-4641 or visit vikingrange.com © 2016 Viking Range, LLC All rights reserved. Specifications subject to change without notice.