



# UNDERCOUNTER WINE CELLARS

15"W. VUWC515GSS and 24"W. VUWC524GSS

## FEATURES

- Storage Capacity
  - 15"W. model:  
Volume of 2.9 cu. ft. holds up to 28 wine bottles (750ml)
  - 24"W. model:  
Volume of 5.2 cu. ft. holds up to 49 wine bottles (750ml)
- Full-depth lower interior maximizes storage options
- Variable speed compressor delivers maximum energy efficiency, faster temperature response, and quieter operation
- Convection cooling system provides a quick cool down and consistent temperature
- Temperature range: 33°F – 70°F
- Stainless steel interior
- Stainless steel cabinet, toe kick, and accents
- Easy adjusting interior with 19 adjustable positions
- Seven removable, full-extension wine racks
- Wine racks accommodate a variety of bottle shapes and sizes and can be configured to store champagne and magnum bottles
- Digital touch pad control with blue LED display
- Adjustable bright white or blue LED lighting
- Soft close door with articulating hinge
- Field reversible door is shipped right-hand hinged
- Built-in or freestanding
- Four adjustable leveling legs

## MODEL NUMBERS

- VUWC515GSS – 15"W. Undercounter Wine Cellar
- VUWC524GSS – 24"W. Undercounter Wine Cellar

## DESIGN OPTIONS

- Product ships as right hinge; field reversible

## COLOR FINISHES

- Available in Stainless Steel (SS)



## WARRANTY

- 2-year full covers complete unit
- 6-year full – sealed refrigeration system
- 90-day full – cosmetic parts such as glass, painted items, and decorative items
- 12-year limited – sealed refrigeration system



UNDERCOUNTER WINE CELLARS		
MODEL	VUWC515GSS	VUWC524GSS
<b>Amps: Running</b>	1.2	
<b>Capacity: Bottle (12 oz)</b>	N/A	
<b>Capacity: Can (12 oz)</b>	N/A	
<b>Capacity Volume (cu ft)</b>	2.9	5.2
<b>Capacity: Wine Bottle (750 ml)</b>	28	49
<b>Dimensions: Product Depth</b>	22 15/16" (583 mm)	
<b>Dimensions: Product Height (Min.)</b>	33 11/16" (855 mm)	
<b>Dimensions: Product Width</b>	14 15/16" (379 mm)	23 5/8" (600 mm)
<b>Energy Consumption: Avg. Per Year</b>	285 kWh	305 kWh
<b>ENERGY STAR (glass door)</b>	No	
<b>Refrigerant Type:</b>	R600a	
<b>Sabbath (Star K Certified)</b>	Yes	
<b>Temperature Range</b>	33°F – 70°F	
<b>Voltage</b>	115/60	
<b>Weight</b>	105 lb.	163 lb.

Please do not prepare installation from brochure data only. See installation instructions for important clearance/installation information.



# UNDERCOUNTER WINE CELLARS

15"W. VUWC515GSS and 24"W. VUWC524GSS

## FRONT

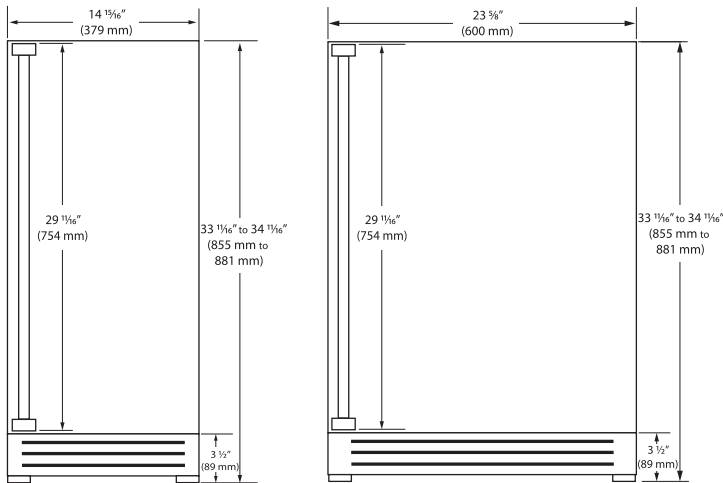

## TOP

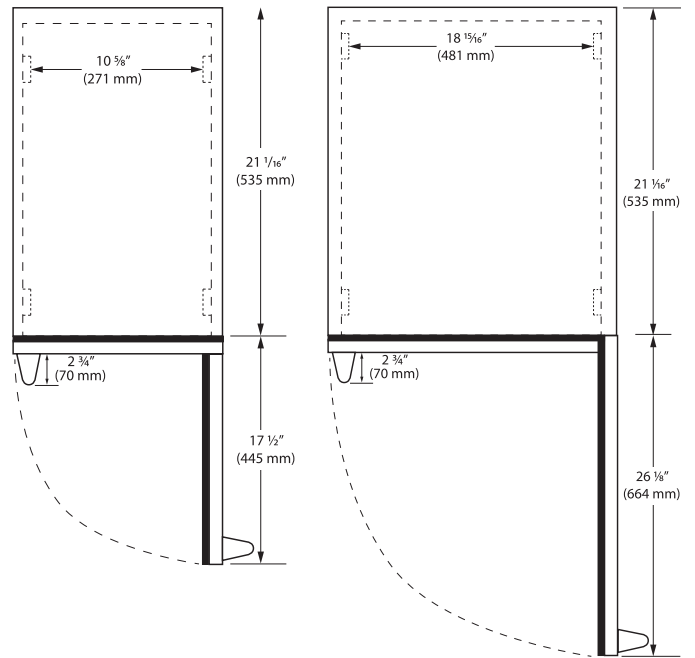

## SIDE

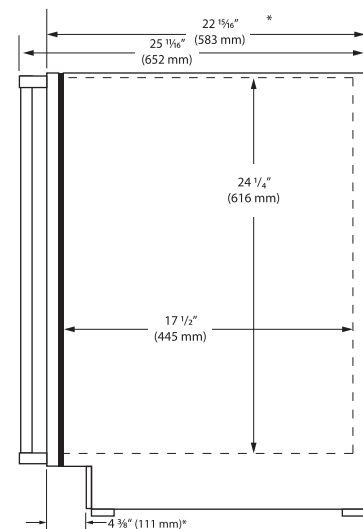

## CUTOUT

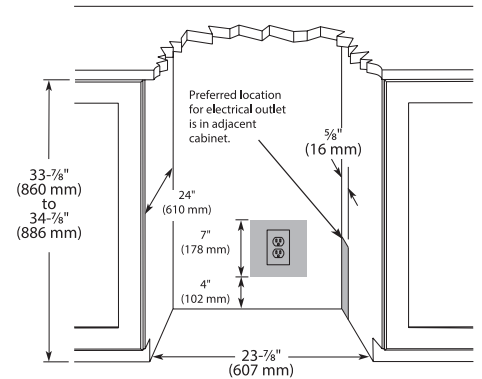
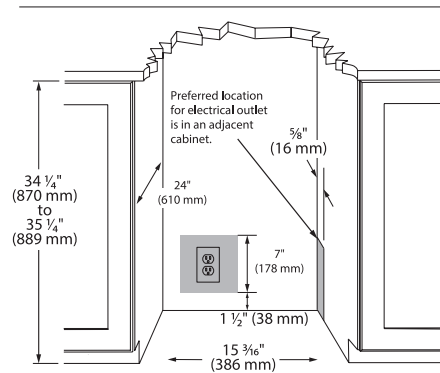

## REAR

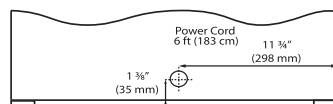
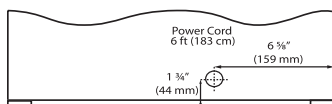

VIKING RANGE, LLC 111 FRONT STREET GREENWOOD, MISSISSIPPI 38930 USA

For detailed product information, model numbers, or to request a quote call 1-888-845-4641 or visit [vikingrange.com](http://vikingrange.com)  
 © 2020 Viking Range, LLC All rights reserved. Specifications subject to change without notice.